

THIRD ANGLE PROJECTION

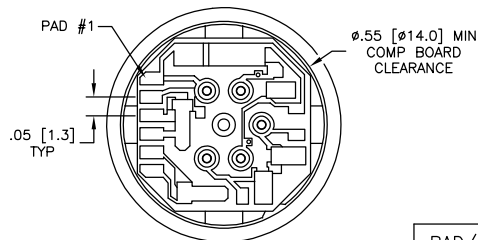
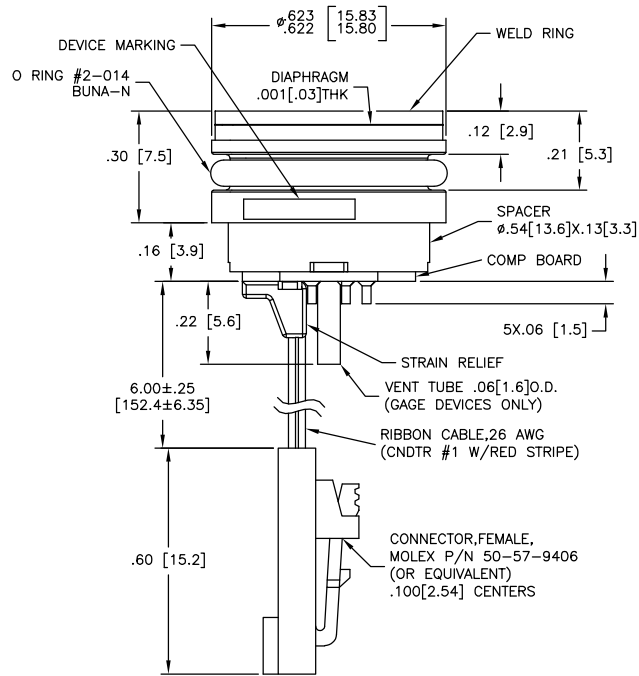
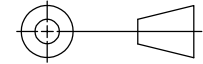

VIEW SHOWN W/O CABLE AND CONNECTOR FOR CLARITY

DIMENSIONS ARE IN INCHES
TOLERANCES (UNLESS SPECIFIED)
XX=.01 XXX=.005 ANGLES=1/2°

PAD/CNDR	FUNCTION
1	+OUT
2	-EX
3	+EX
4	-OUT
5	GAIN
6	

UNLESS OTHERWISE SPECIFIED:  
ALL PARAMETERS ARE MEASURED AT 1.5mA AND AT 25°C

PARAMETERS	005 PSI			≥015PSI			UNITS	NOTES	
	MIN	TYP	MAX	MIN	TYP	MAX			
SPAN	50	100	150	75	100	150	mV	1	
ZERO PRESSURE OUTPUT	-2.0	0	+2.0	-1.0	0	+1.0	mV	2	
PRESSURE NON-LINEARITY	-0.20	-	+0.20	-0.10	-	+0.10	% SPAN	3	
PRESSURE HYSTERESIS	-0.10	±0.02	+0.10	-0.05	±0.02	+0.05	% SPAN		
REPEATABILITY	-	±0.02	-	-	±0.02	-	% SPAN		
INPUT RESISTANCE	2.5K	5.0K	6.5K	2.0K	3.5K	5.8K	Ω		
OUTPUT RESISTANCE	4.0K	-	7.0K	4.0K	-	6.0K	Ω		
TEMPERATURE ERROR, SPAN	-1.0	-	+1.0	-0.75	-	+0.75	% SPAN	4	
TEMPERATURE ERROR, OFFSET	-2.5	-	+2.5	-0.50	-	+0.50	% SPAN	4,5	
THERMAL HYSTERESIS, SPAN	-0.25	±0.05	+0.25	-0.25	±0.05	+0.25	% SPAN	4	
THERMAL HYSTERESIS, OFFSET	-0.25	±0.05	+0.25	-0.25	±0.05	+0.25	% SPAN	4	
LONG TERM STABILITY, SPAN	-	±0.10	-	-	±0.10	-	% SPAN/YR		
LONG TERM STABILITY, OFFSET	-	±0.25	-	-	±0.10	-	% SPAN/YR		
SUPPLY CURRENT	0.5	1.5	2.0	0.5	1.5	2.0	mA	6	
OUTPUT LOAD RESISTANCE	5M	-	-	5M	-	-	Ω	7	
INSULATION RESISTANCE (50 VDC)	50M	-	-	50M	-	-	Ω	8	
OUTPUT NOISE (10Hz to 1kHz)	-	1.0	-	-	1.0	-	µV p-p		
RISE TIME (10% to 90%)	-	-	0.1	-	-	0.1	mS		
PROOF PRESSURE	-	-	3X	-	-	3X	RATED		
BURST PRESSURE	-	-	4X	-	-	4X	RATED	9	
COMPENSATED TEMPERATURE	0	-	+50	-20	-	+85	°C		
OPERATING TEMPERATURE	-20	-	+70	-40	-	+125	°C	10	
STORAGE TEMPERATURE	-50	-	+125	-50	-	+125	°C	10	
MEDIA, PRESSURE PORT	LIQUIDS AND GASES COMPATIBLE WITH 316/316L ST STL								

### ORDERING INFORMATION

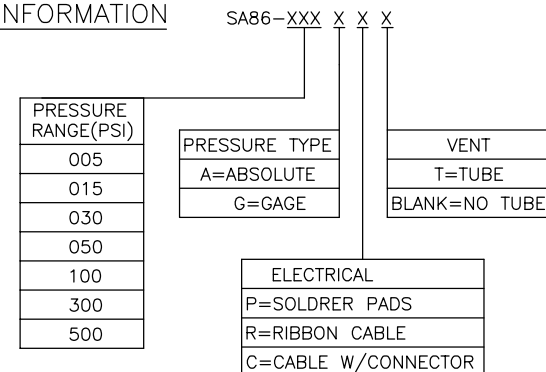

THIRD ANGLE PROJECTION

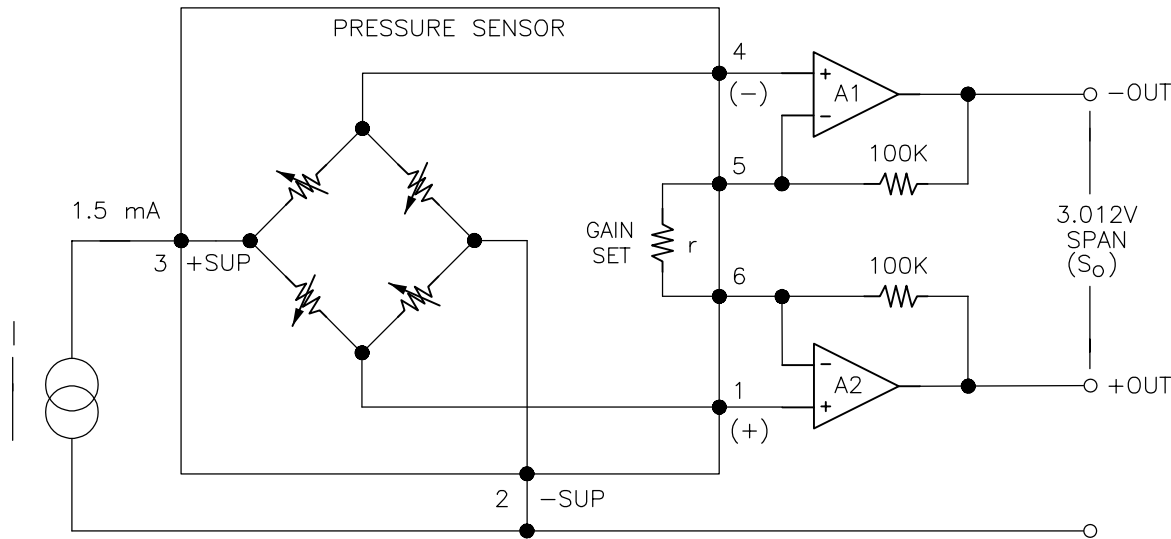
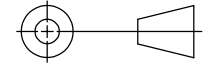

APPLICATION SCHEMATIC

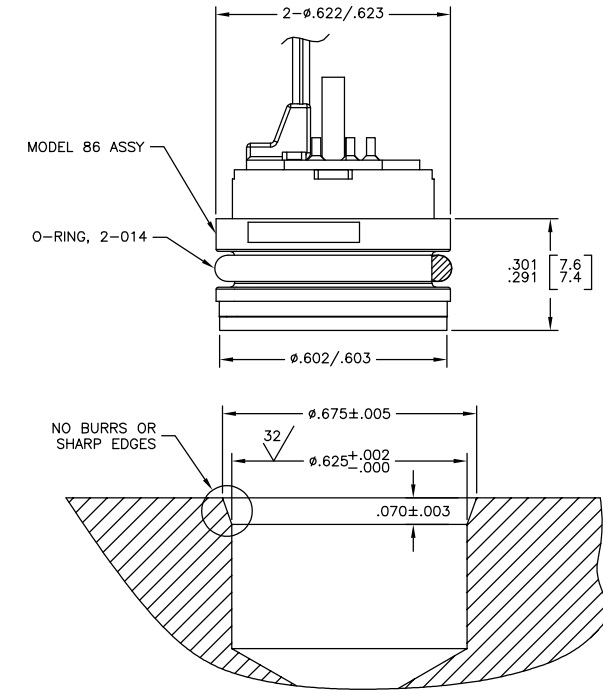

RECOMMENDED MOUNTING DIMENSIONS

## Notes

1. For amplified output circuits, 3.012V  $\pm$ 1% interchangeability with gain set resistor. See application schematic.
2. Measured at vacuum for absolute (A), ambient for gage (G).
3. Best fit straight line.
4. Over the compensated temperature range with respect to 25°C.
5. 15psi range sensors have a temperature error -offset of  $\pm$ 0.75% (max).
6. Guarantees output/input ratiometricity.
7. Load resistance to reduce measurement errors due to output loading.
8. Between case and sensing element.
9. The maximum pressure that can be applied to a transducer without rupture of either the sensing element or transducer.
10. Maximum temperature range for product with standard cable and connector is -20 to +105°C.
11. Standard Gage Units are not recommended for vacuum applications. For vacuum applications below 1/2 atmosphere, consult factory.
12. Device marking:  
Each part shall be identified with Model Number, Pressure Range, Type, lot Number, Serial number and Date Code.
13. Shipping/Packaging requirements:  
The stainless steel diaphragm is protected by a plastic CAP. Each unit will be packaged individually in a plastic vial with anti-static foam.
14. Direct mechanical Contact with diaphragm is prohibited. Diaphragm surface must remain free of defects (scratches, punctures, dents, fingerprints, etc) for device to operate properly. Caution is advised when handling parts with exposed diaphragms. Use protective cap whenever devices are not in use.